

LIAISON LYON - TURIN / COLLEGAMENTO TORINO - LIONE

Partie commune franco-italienne
Section transfrontalière

Parte comune italo-francese
Sezione transfrontaliera

NOUVELLE LIGNE LYON TURIN - NUOVA LINEA TORINO LIONE PARTIE COMMUNE FRANCO - ITALIENNE - PARTE COMUNE ITALO - FRANCESE

REVISION DE L'AVANT PROJET DE REFERENCE - REVISIONE DEL PROGETTO DEFINITIVO
CUP J11J05000030001

OTTEMPERANZA ALLE PRESCRIZIONI DELLA DELIBERA CIPE 57/2011

Prescrizione n. 196
Infopoint Caserma Clemente Henry - Susa

PROGETTO DEFINITIVO
Architettonico

FASE 1 - Fase Infopoint: Abaco dei solai

| Indice | Data | Modifiche | Concepito da | Controllato da | Validato da |
|--------|---------------|-------------------------|---------------|----------------|--|
| 0 | Dicembre 2012 | Emissione | Massimo Rigat | Lorenzo Morra | Adriano Venturini |
| A | Febbraio 2013 | Emissione allo stato AP | Massimo Rigat | Lorenzo Morra | Adriano Venturini |
| B | Marzo 2013 | Emissione Fase 1 - AP | Massimo Rigat | Lorenzo Morra | Adriano Venturini |
| | | | | | Doc. Ing. ADRIANO VENTURINI ADSTA 287 |
| | | | | | |
| | | | | | |
| | | | | | |

| | | | | | | | | | | | | | | | | | | | |
|-----|------|---|---|-------|---|---|-----------|---|---|--------|---|---|---|--------|-------|---|------|---|---|
| N° | P | D | 2 | H | E | N | G | I | A | 0 | 2 | 1 | 4 | B | A | P | P | L | A |
| Doc | Fase | | | Sigla | | | Emittente | | | Numero | | | | Indice | Stato | | Tipo | | |

INDIRIZZO GED / ADRESSE GED MS6 \ \ 01 97 02 30 13

SCALA
1:10

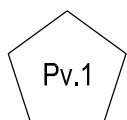

PAVIMENTAZIONE IN ASFALTO (SOLO SCARIFICA)

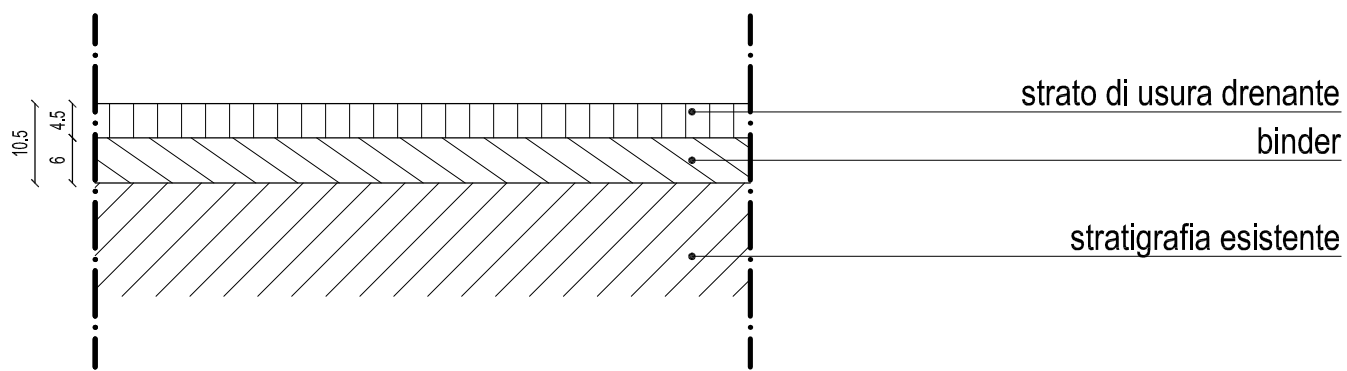

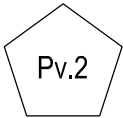

PAVIMENTAZIONE IN CUBETTI DI PIETRA AUTOCTONA

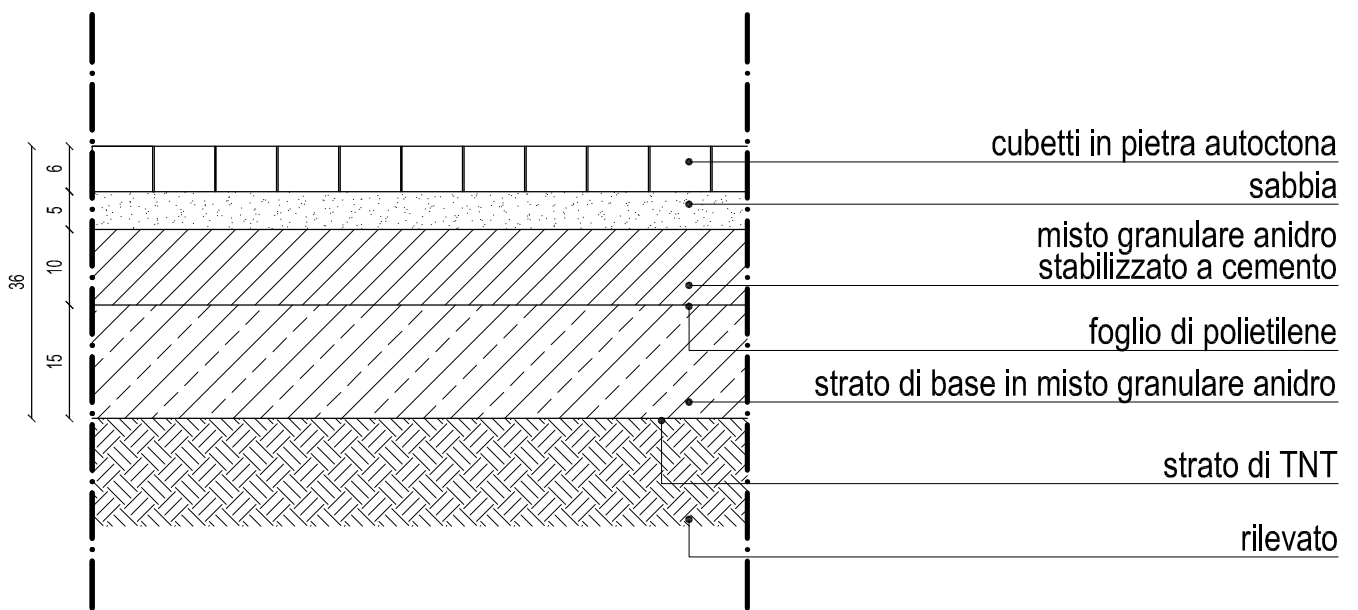

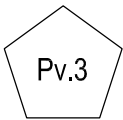

PAVIMENTAZIONE IN CLS DISATTIVATO

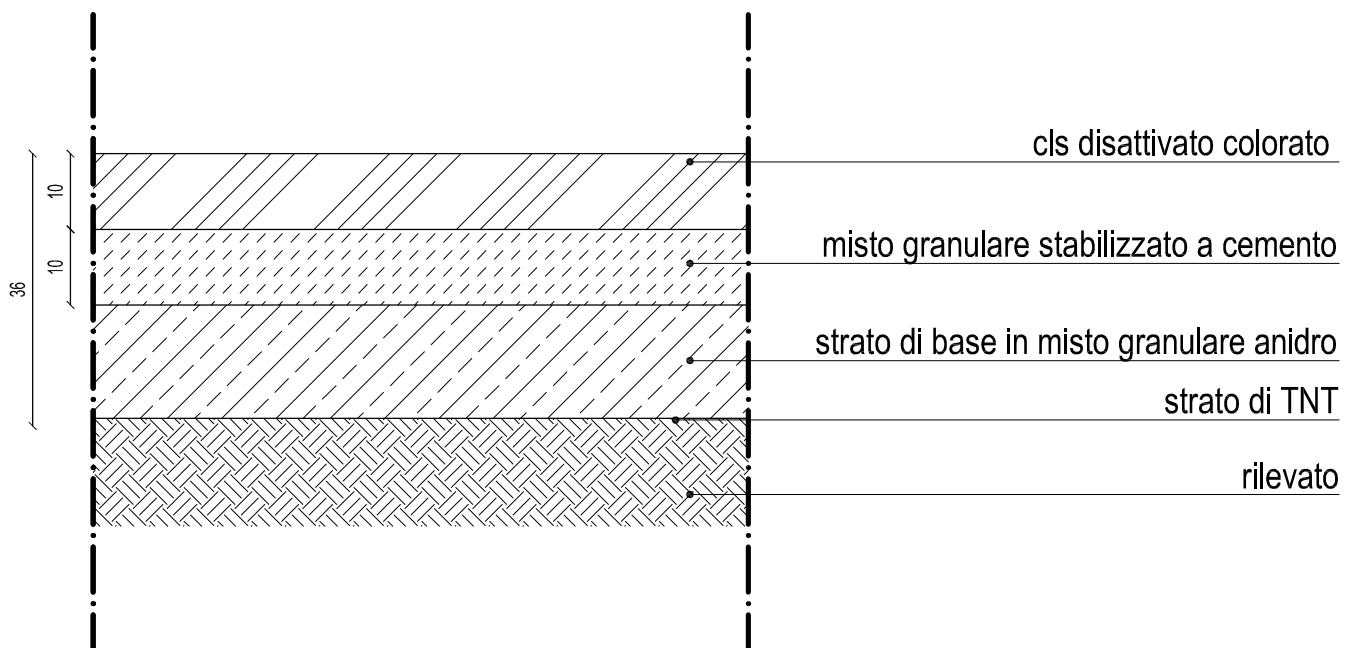

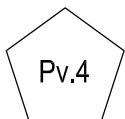

SOLAIO SPAZIO ESPOSITIVO PIANO TERRA

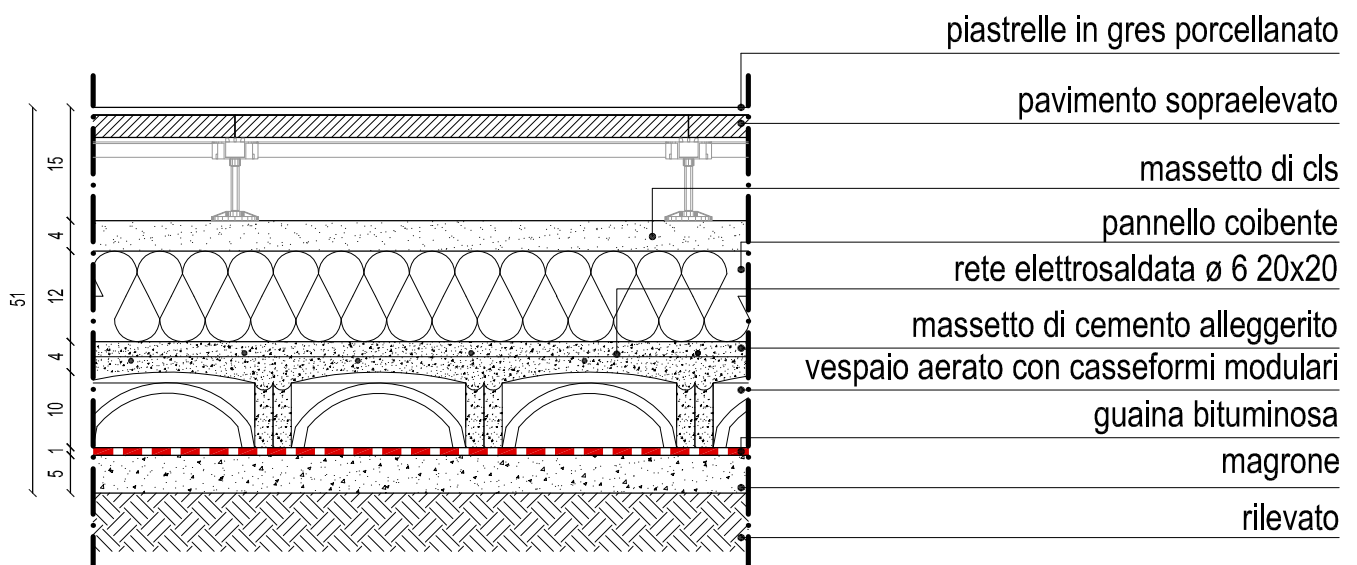

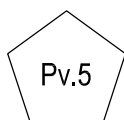

SOLAIO SERVIZI PIANO TERRA

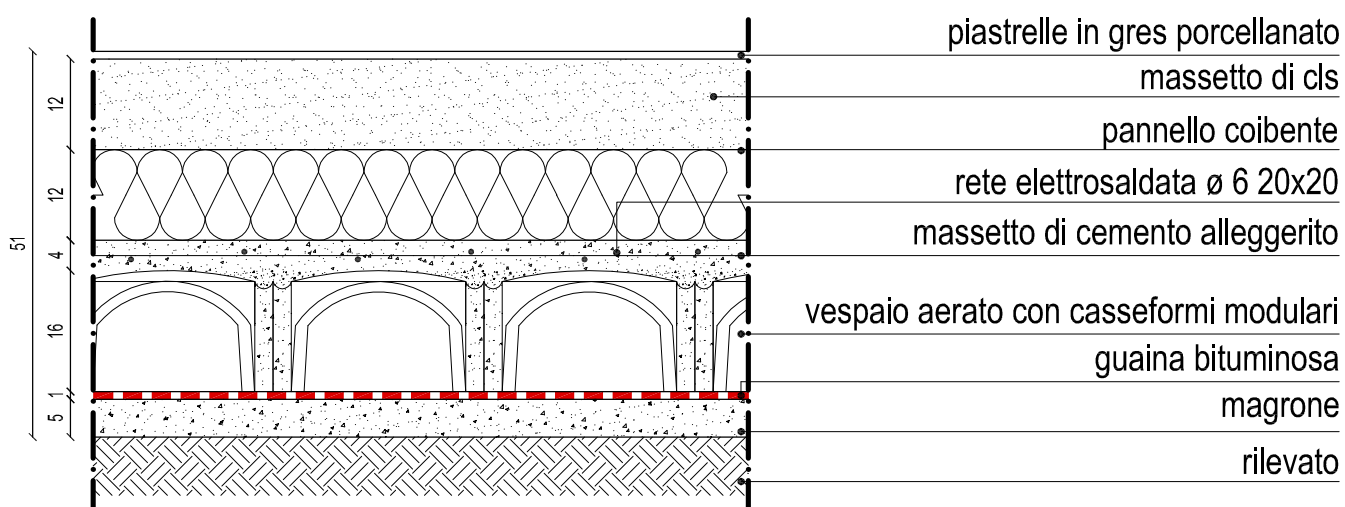

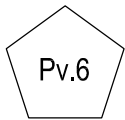

SOLAIO LOCALI TECNICI PIANO TERRA

